



# FORNO CLASSICO NAPOLI SERIES

RESIDENTIAL NAPOLI 2020

[WWW.FORNOCLASSICO.COM](http://WWW.FORNOCLASSICO.COM)





# FORNO CLASSICO



RESIDENTIAL NAPOLI

**performance..elegance..Italian design**

Giuseppe spent three years designing and fine-tuning the Forno Classico Napoli residential pizza oven. He combined all the key learnings that he had heard directly from his customers and knew exactly what they wanted. A contemporary design with a modern feel – think Lamborghini: sharp design combining the beauty of a woman and the fire of a man – aggressive high performance and stellar efficiency. Meticulously crafted down to every detail with its stainless steel front, precise temperature reading and centered chimney, the Forno Classico Napoli pizza oven easily passed its rigorous certification testing bringing the best pizza oven on to the market today.



# HYBRID



## HYBRID (GAS) NAPOLI PIZZA OVEN

When selecting a pizza oven, keep in mind that if you choose a gas oven you are choosing a hybrid because our gas pizza ovens can use wood and gas together, or just gas. Both heat sources (gas and wood) can reach 1000 degrees in a short period of time, 30 - 40 minutes. The benefit of a hybrid oven is that you can maximize your use of gas and reach the desired temperature of 1000 degrees quickly. Then, you can lower the gas, add and light a piece of wood (one small log) to maintain the temperature and impart the desired smoke and flavor to your food.



## OUR FORNO CLASSICO GAS BURNER

Forno Classico created and designed a propriety gas burner for our pizza ovens with efficiency and low maintenance top of mind. We set out to re-create a soft wood flame — gas burners are notorious for being too aggressive and often just too hot. We wanted a softer, consistent flame that would brown and roast food, not burn it. Our founder, Giuseppe Crisa designed the burner himself - first, he removed the electricity from the burner system to simplify it which makes the burner more efficient and allows for low, to no maintenance. The Forno Classico gas burner is heavy duty, retains its own safety valve with a regulator, and has an adjustable flame. Made with 100% stainless steel, corrosion is a thing of the past.



# FIRST LOOK



## WHY CHOOSE THE NAPOLI PIZZA OVEN

The Forno Classico Napoli pizza oven is the top of our residential pizza oven line – a Ferrari in performance and efficiency. The oven can maintain a 1,000 degree temperature. This temperature instantaneously sears the food, resulting in the perfect marriage of a crispy exterior while maintaining a moist interior. Our unique design allows the highest quality cooking performance and an unparalleled ability to generate high heat cooking not often seen in other residential pizza ovens. The superior engineering of the Napoli pizza oven allows for perfect alignment of the oven's brick floor with its low dome. This highly efficient design results in a superior cooking time and mouth watering Italian pizza.



# FEATURES











Copyright © 2016 - Forno Classico





# FEATURES



 <p><b>Fast cooking temperature</b> Low dome design requires only one minute to cook</p>	 <p><b>Gas efficiency</b> Only 65.000 BTU required to reach 1000 degrees F</p>	 <p><b>Recycling exhaust Fumes</b> We design our ovens to recycle exhaust fumes to provide maximum heating efficiency</p>	 <p><b>Building with Natural product</b> We use all natural products in the building of our ovens</p>	 <p><b>Insulation</b> Superior Insulating Materials used to create excellent performance</p>
 <p><b>No Electricity Required</b> Our Oven can be installed without any electricity</p>	 <p><b>Water Approved</b> Designed and Listed for Indoor and Outdoor Installation</p>	<p><b>HYBRID</b> <b>Use Wood and Gas Combo</b> Our hybrid design allows use of both wood and gas for maximum performance</p>	 <p><b>All Natural Fire Brick</b> We use natural firebrick to build our ovens because it provides the most efficient heating</p>	 <p><b>Fire Brick Constriction</b> Single piece oven floor and dome</p>



Forno Classico is NSF & CSA Approved Our pizza ovens are certified by the NSF and CSA to adhere to residential codes throughout the US and Canada



VARIETY OF RECIPES







**Mosaic tile color**

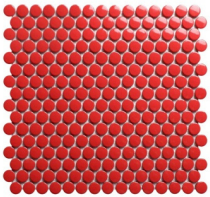

Penny Round Glossy Red

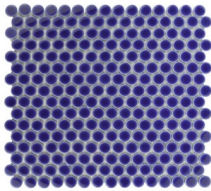

Penny Round Glossy Cobalt Blue

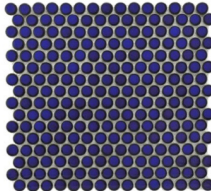

Penny Round Glossy Blue Eye

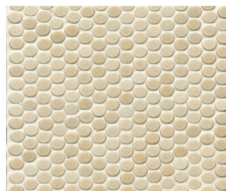

Beige

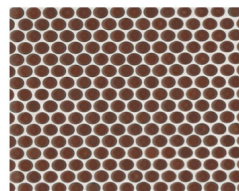

Cardinal

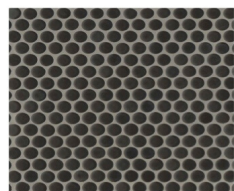

Charcoal



Penny Round Matte White



Penny Round Glossy White

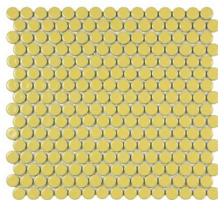

Penny Round Glossy Vintage Yellow

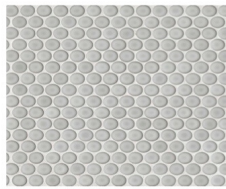

Dove Grey

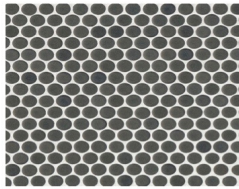

Iron

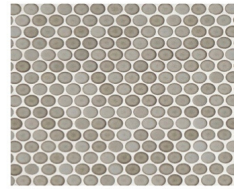

Pumice

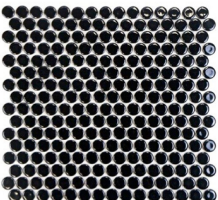

Penny Round Glossy Black

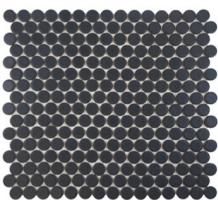

Penny Round Matte Black

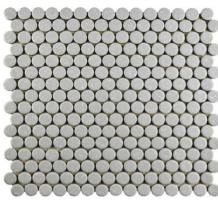

Penny Round Crystalline Grey

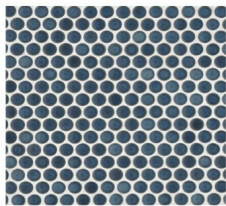

Lagoon

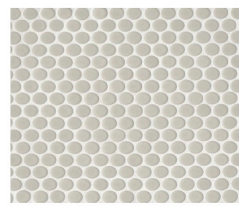

Off white

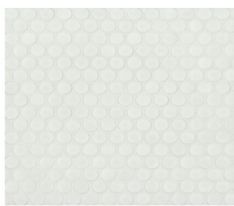

White Matte

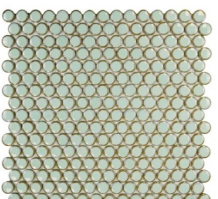

Penny Round Glossy Light Green

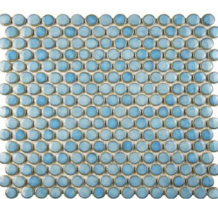

Penny Round Marine

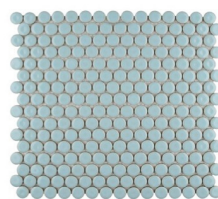

Penny Round Cashmere Blue

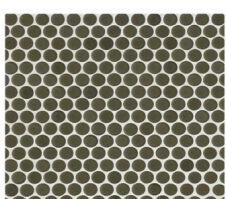

Shale

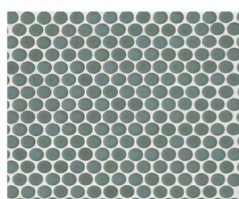

Silver

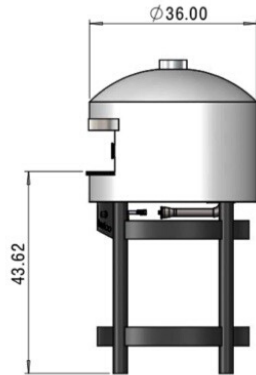
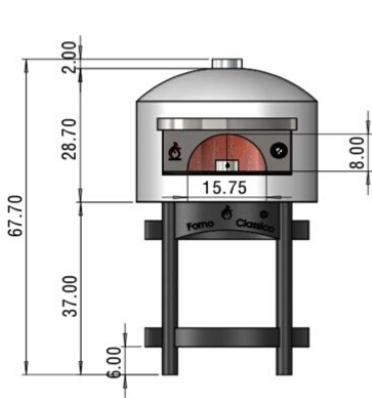

# FEATURE

## SPECIFICATION NAPOLI 65

Cooking Floor Dimension: 26" inches  
 External Size: 36" Weight: 1,000 lbs

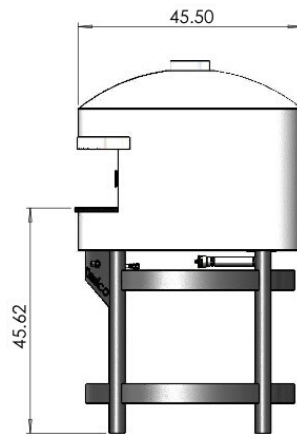
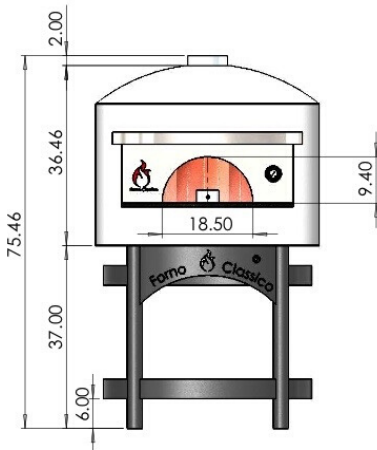

## SPECIFICATION NAPOLI 80

Cooking Floor Dimension: 32 inches Round  
 External Size: 45.1/2" Weight: 1,300 lbs

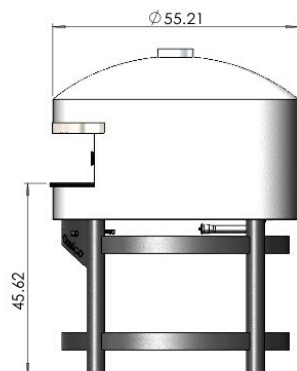
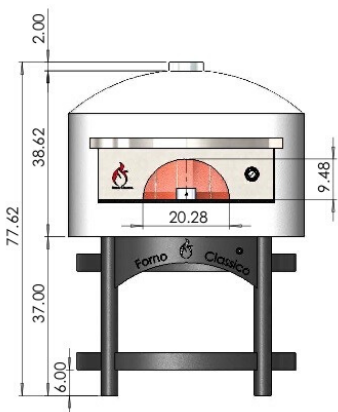

## SPECIFICATION NAPOLI 100

Cooking Floor Dimension: 40 inches Round  
 External Size: 55" 1/2" Weight: 2,000 lbs



THE NAPOLI



[WWW.FORNOCLASSICO.COM](http://WWW.FORNOCLASSICO.COM)